



TOWN OF RIDGEFIELD

Building Department

As owner of the property located at _____

I Hear By Acknowledge the Following:

- ✓ I have received the booklet entitled, "Swimming Pool, Spa and Hot Tub Requirements," from the Town of Ridgefield Building Department.
- ✓ I acknowledge that the requirements contained in the booklet are part of the 2018 Connecticut State Building Code.
- ✓ The Swimming Pool, Pool & Spa, or Hot Tub to be installed on my property will comply with all pertinent Building Code requirements as contained in the booklet.
- ✓ The pertinent Building Code requirements contained in the booklet will be completed prior to the final inspection and issuance of the Certificate of Occupancy.
- ✓ And as owner I will be responsible for the installation and maintenance of all temporary fencing and safety devises prior to the commencement of the installation of any in-ground swimming pool unless a permanent barrier is in place prior to the commencement of the installation.

Owner's Signature _____ Date _____

Owner's Name _____
Printed or Typed

Note* This form must be signed by the owner in Community Development office or the signature must be notarized.

Saved: wordformspoolpage11/27/18

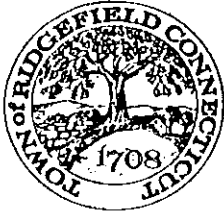

TOWN OF RIDGEFIELD

Building Department

66 Prospect Street, Ridgefield, CT 06877

(203) 431-2743 t • (203) 431-2737 f

SWIMMING POOLS SPAS & HOT TUBS REQUIREMENTS

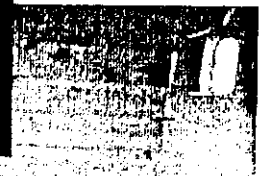
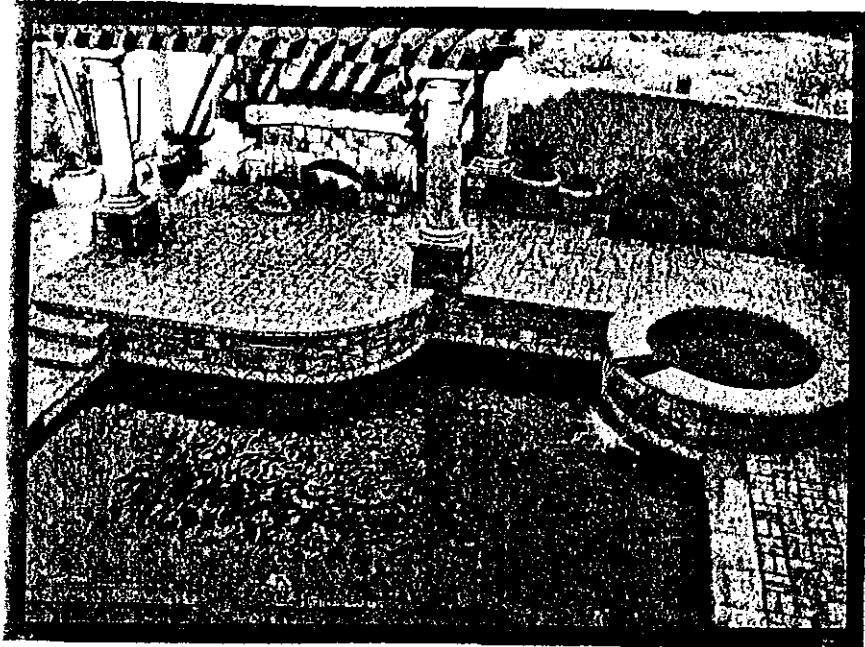

Typical position of tip of board relative to Pt. A

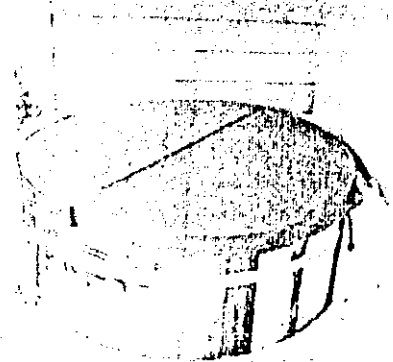
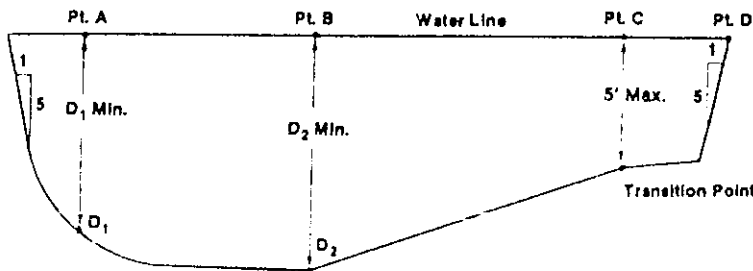

Town of Ridgefield
Town Hall Annex – 66 Prospect Street
Ridgefield, CT 06877 - ph (203)431-2743

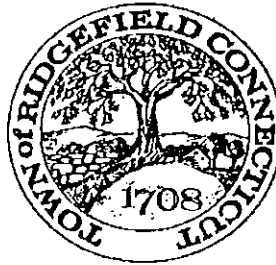

BUILDING DEPARTMENT

SWIMMING POOL SPA & HOT TUB REQUIREMENTS

(Code Change effective 5/1/99)

New legislation affecting Building Officials *(continued from P. 11)*

PA 99-140 requires an additional pool alarm for residential swimming pools for one or more families before a permit can be issued for a new pool or substantial alteration of an existing pool. The alarm must emit a sound of 50 decibels when a 15 pound object enters the water. The alarm is in addition to all other pool barrier requirements. The law is effective October 1, 1999.

**Town of Ridgefield Building Department
Town Hall Annex – 66 Prospect St**

OFFICE HOURS: 8AM - 4PM – MONDAY THRU FRIDAY – PHONE (203)431-2743

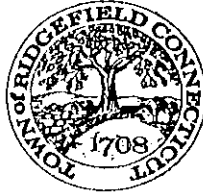

Required Pool Inspections

1. **REBAR / STRUCTURAL / SOIL INSPECTIONS:** All rebar to be supported for concrete encasement. *Note Use of wood or clay brick not acceptable as support.
2. **BONDING:** Metal parts, per section E 4104 of the International Residential Code. Needs to be inspected before covering.

FOR POOL & SPA

3. **UNDERGROUND PIPING:** To skimmers, drains, etc. Needs to be inspected before covering.
4. **UNDERGROUND WIRING:** From house to pool, pool lighting, etc. Needs to be inspected before covering and access to house is required.
5. **FINAL INSPECTION FOR CO:** Before scheduling final inspection, approval from Planning & Zoning (ie; As Built Survey), is required. All fencing, gates, closures, pool and surrounding work needs to be complete.

Note Underground Piping and Wiring will be inspected at the same time. Reinspection fee is \$25.00. This fee is paid when Inspection is scheduled and job is not ready.*

(Add) **R326.6 Barrier requirements.** The provisions of this section *shall* control the design of barriers for residential *swimming pools*, spas and hot tubs. These design controls are intended to provide protection against potential drownings, and near-drownings by restricting access to *swimming pools*, spas and hot tubs.

(Add) **R326.6.1 Outdoor swimming pool.** An outdoor swimming pool, including an in-ground, above-ground or on-ground pool, hot tub or spa, *shall* be surrounded by a barrier which *shall* comply with the following:

1. The top of the barrier *shall* be at least 48 inches (1219 mm) above grade measured on the side of the barrier which faces away from the swimming pool. The maximum vertical clearance between grade and the bottom of the barrier *shall* be 2 inches (51 mm) measured on the side of the barrier which faces away from the swimming pool. Where the top of the pool structure is above grade, such as an above-ground pool, the barrier may be at ground level, such as the pool structure, or mounted on top of the pool structure. Where the barrier is mounted on top of the pool structure, the maximum vertical clearance between the top of the pool structure and the bottom of the barrier *shall* be 4 inches (102 mm).
2. Openings in the barrier *shall* not allow the passage of a 4-inch-diameter (102 mm) sphere.
3. Solid barriers which do not have openings, such as a *masonry* or stone wall, *shall* not contain indentations or protrusions, except for normal construction tolerances and tooled *masonry* joints.
4. Where the barrier is composed of horizontal and vertical members, and the distance between the tops of the horizontal members is less than 45 inches (1143 mm), the horizontal members *shall* be located on the swimming pool side of the fence. Spacing between vertical members *shall* not exceed 1¾-inches (44 mm) in width. Where there are decorative cutouts within vertical members, spacing within the cutouts *shall* not exceed 1¾-inches (44 mm) in width.
5. Where the barrier is composed of horizontal and vertical members, and the distance between the tops of the horizontal members is 45 inches (1143 mm) or more, spacing between vertical members *shall* not exceed 4 inches (102 mm). Where there are decorative cutouts within vertical members, spacing within the cutouts *shall* not exceed 1¾-inches (44 mm) in width.
6. Maximum mesh size for chain link fences *shall* be a 2¼-inch (57 mm) square, unless the fence has slats fastened at the top or the bottom which reduce the openings to not more than 1¾-inches (44 mm).
7. Where the barrier is composed of diagonal members, such as a lattice fence, the maximum opening formed by the diagonal members *shall* not be more than 1¾ inches (44 mm).
8. Access gates *shall* comply with the requirements of Items 1 through 7, and *shall* be equipped to accommodate a locking device. Pedestrian access gates *shall* open outward away from the pool, and *shall* be *self-closing* and have a self-latching device. Gates, other than pedestrian access gates, *shall* have a self-latching device. Where the release mechanism of the self-latching device is located less than 54 inches (1372 mm) from the bottom of the gate, the release mechanism and openings *shall* comply with the following:
 - 8.1 The release mechanism *shall* be located on the pool side of the gate at least 3 inches (76 mm) below the top of the gate; and
 - 8.2 The gate and barrier *shall* have no opening larger than 1/2 inch (12.7 mm) within 18 inches (457 mm) of the release mechanism.

(Add) R 326.1 Outdoor swimming pool cont'd

9. Where a wall of a *dwelling* serves as part of the barrier, one of the following conditions *shall* be met:
 - 9.1 The pool *shall* be equipped with a powered safety cover in compliance with ASTM F1346;
 - 9.2 Doors with direct access to the pool through that wall *shall* be equipped with an alarm that produces an audible warning when the door and/or its screen, if present, are opened. The alarm *shall* be *listed and labeled* in accordance with UL 2017. The deactivation switch(es) *shall* be located at least 54 inches (1372 mm) above the threshold of the door; or
 - 9.3 Other means of protection, such as *self-closing* doors with self-latching devices, which are *approved* by the governing body, *shall* be acceptable as long as the degree of protection afforded is not less than the protection afforded by Item 9.1 or 9.2 described herein.
10. Where an above-ground or on-ground pool structure is used as a barrier or where the barrier is mounted on top of the pool structure, and the means of access is a ladder or steps, the ladder or steps *shall* be surrounded by a barrier that meets the requirements of Section AG105.2, Items 1 to 9, inclusive.

(Add) R326.6.2 Indoor swimming pool. Walls surrounding an indoor swimming pool *shall* comply with Item 9 of Section R326.6.1.

(Add) R326.6.3 Barrier perimeter clearance. The required barrier height *shall* exist around the entire perimeter of the barrier and for a distance of 3 feet (914 mm) measured horizontally from the outside of the required barrier, free of structures, equipment or similar objects.

(Add) R326.6.4 Barrier exceptions. Spas or hot tubs with a safety cover which comply with ASTM F1346 *shall* be exempt from the provisions of this chapter.

(Add) R326.6.5 Temporary enclosure. A temporary enclosure *shall* be installed prior to the electrical bonding inspection of any in-ground swimming pool unless the permanent barrier specified in Section R326.6.1 is in place prior to the commencement of the installation. The temporary enclosure *shall* be a minimum of 4 feet (1219) in height, *shall* have no openings that will allow passage of a 4-inch (102 mm) sphere and *shall* be equipped with a positive latching device on any openings.

(Add) R326.6.6 Pool alarm. Pursuant to section 29-265a of the Connecticut General Statutes, no building *permit shall* be issued for the construction or substantial *alteration* of a swimming pool at a residence occupied by, or being built for, one or more families unless a pool alarm is installed with the swimming pool. As used in this section, "pool alarm" means a device that emits a sound of at least 50 decibels when a person or an object weighing 15 pounds (6.8 kg) or more enters the water in a swimming pool.

Exception: Hot tubs and portable spas *shall* be exempt from this requirement.

(Add) R326.7 Entrapment protection for swimming pool and spa suction outlets. Suction outlets *shall* be installed in accordance with APSP 7.

Barriers Required to Prevent Access



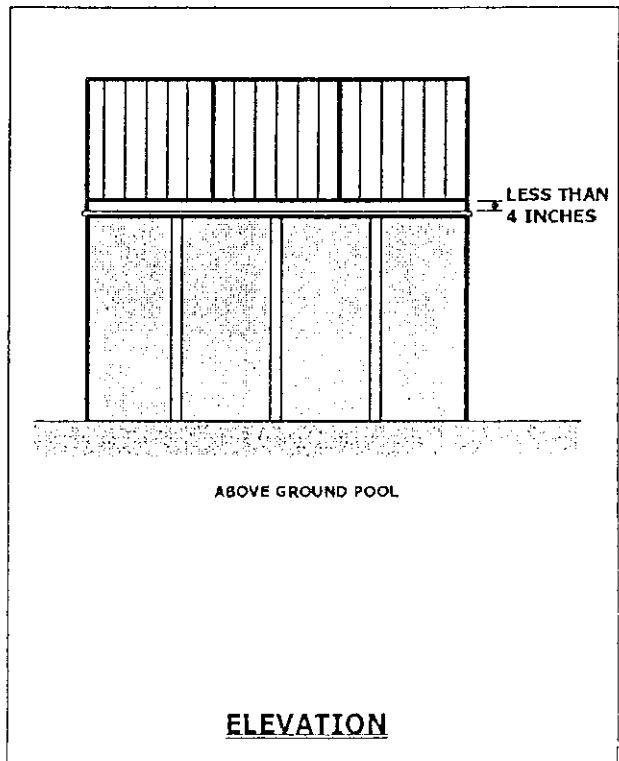
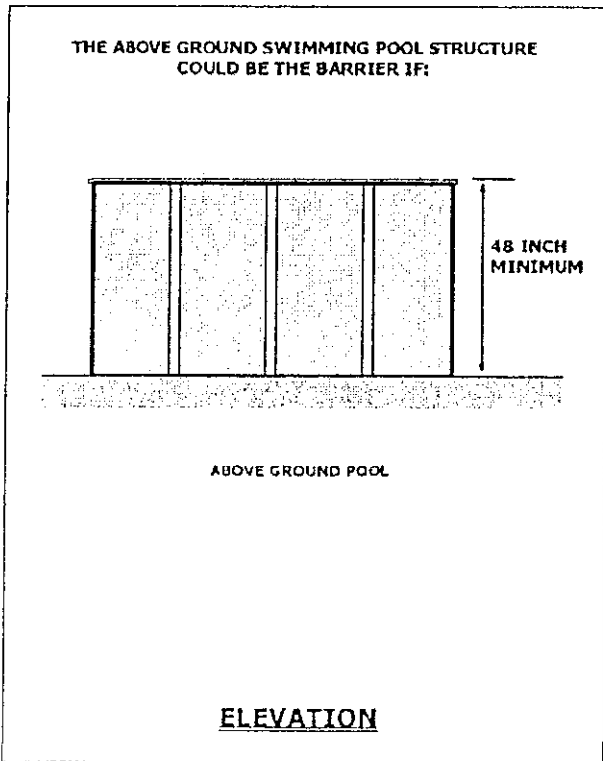
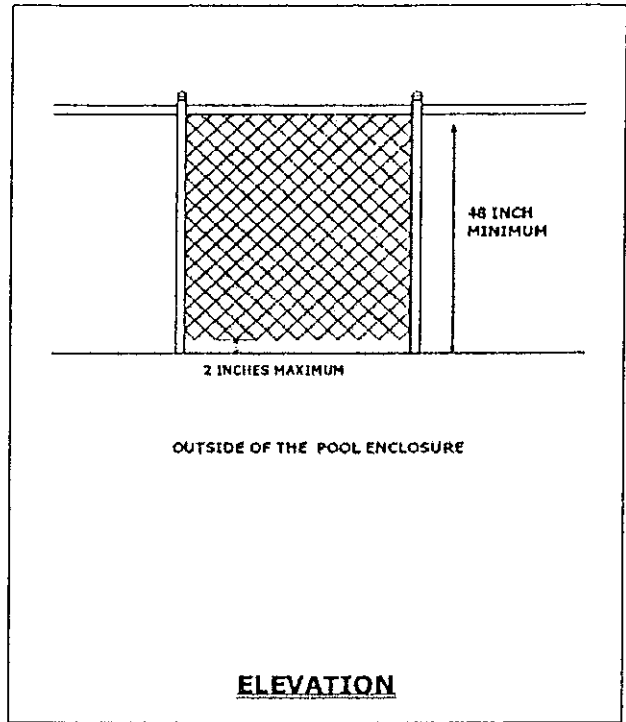
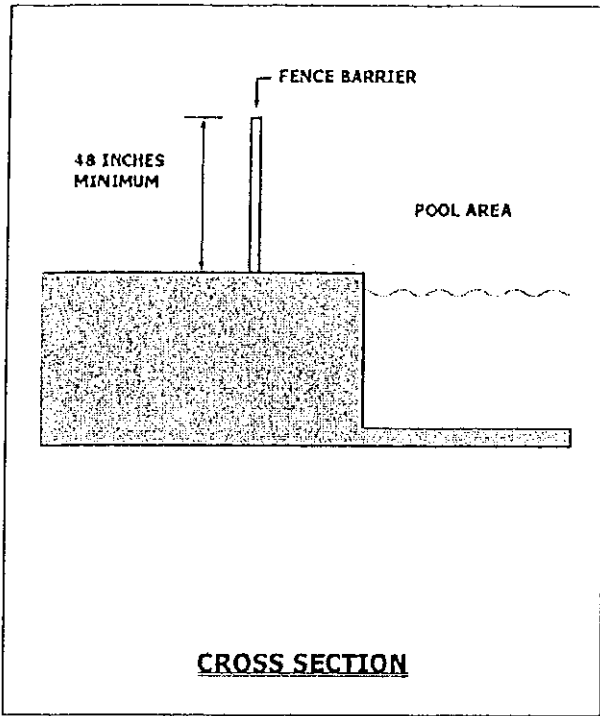

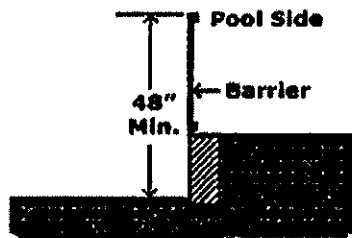

When there is a differential in grade, the barrier height is measured on the side away from the pool.

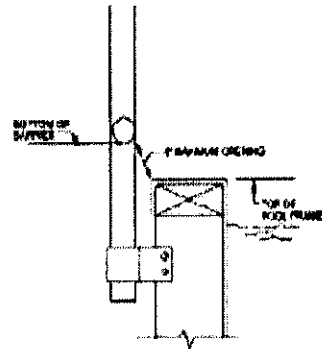

3. No protrusions

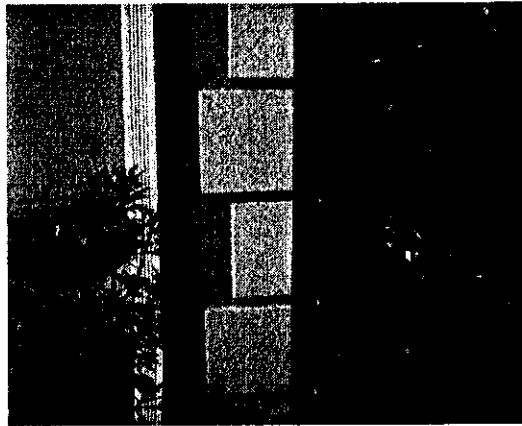

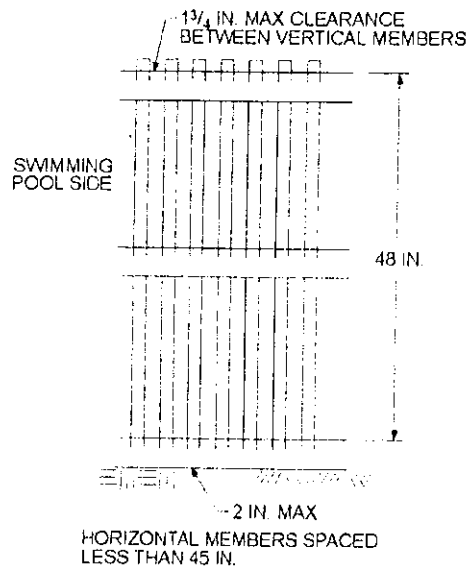
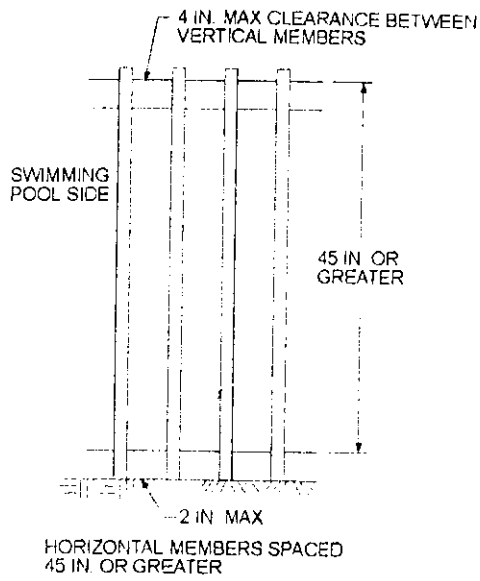

For SI: 1 inch = 25.4 mm.

6. Chain link dimensions

Mesh size 2-1/4" square max.

Slats fastened at top or bottom, reduce to 1-3/4"

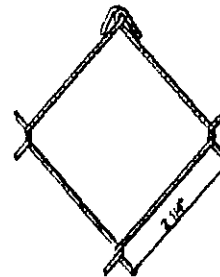

FIGURE 11B-1.1

Figure 11B-1.1
CHAIN-LINK FENCE MESH FOR PRIVATE
MEMBER POOLS

8. Access gates:

Comply with 1 – 7, *plus*

- Accommodate a locking device
- Open outward
- Self-closing, Self-latching
- Other gates self-latching
- Release mechanism less than 54" above bottom of gate:
 - Pool side, at least 3" below top of gate,
 - No opening greater than 1/2" within 18"



When the release mechanism is located less than 54" above the bottom of the gate, it must be on the pool side of the fence and at least 3" below the top of the fence. Otherwise, it can be on the outside.

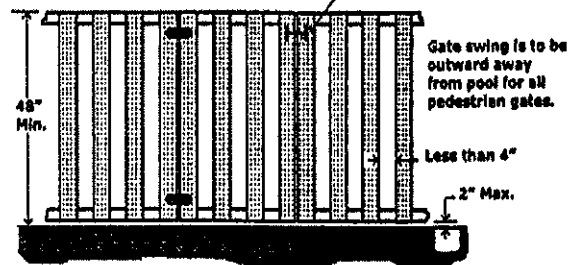

All pool gates must be self-latching and equipped with locking devices. Pedestrian gates must also be self-closing.

7. Diagonal members:
1-3/4" maximum
openings

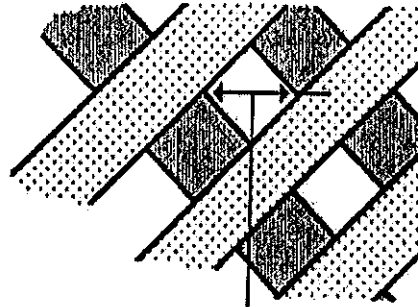

Barriers formed of diagonal members shall not have openings larger than 1 3/4" (44mm)

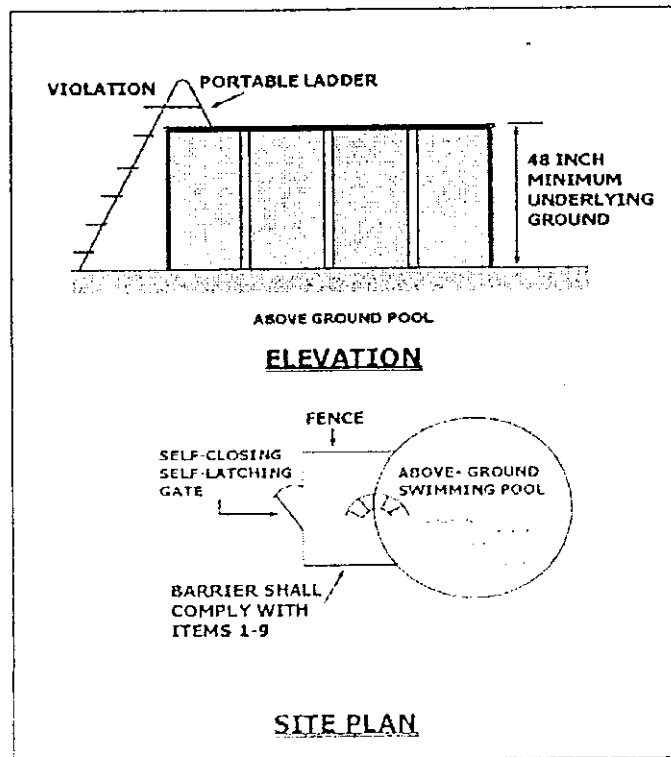
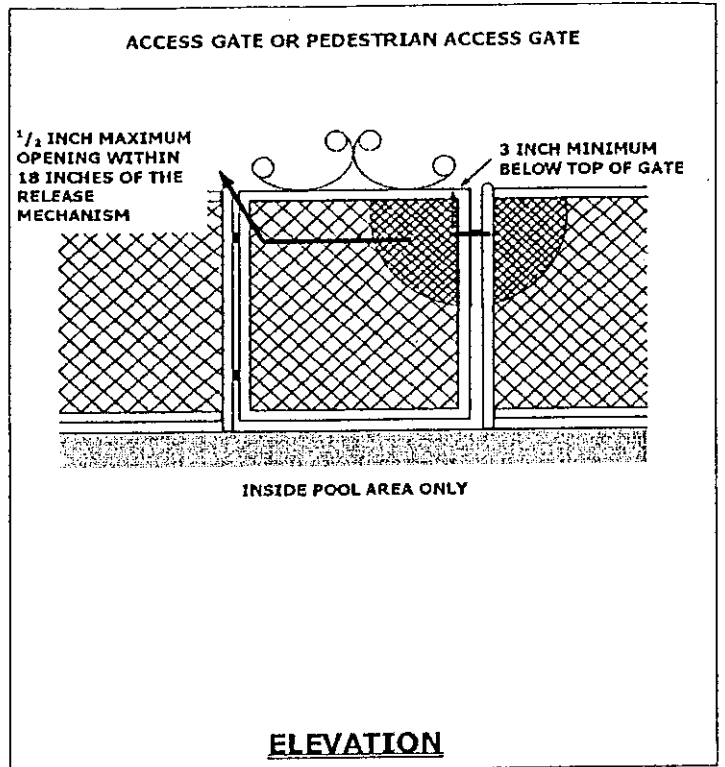
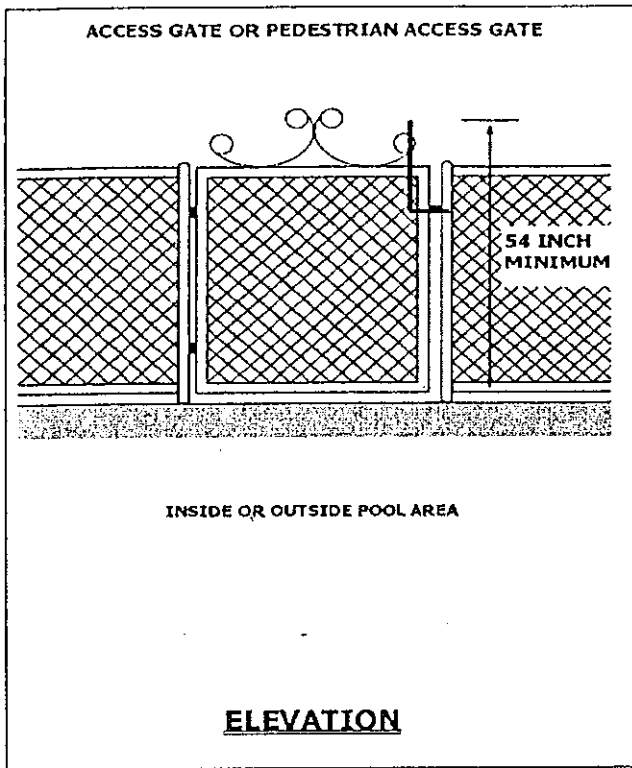

THE DOOR ALARM SHALL:

- Produce an audible warning when the door and its screen are opened.
- Audible warning sounds within 7 seconds of opening the door and
- Sound continuously for 30 seconds minimum.
- Have a minimum sound pressure rating of 85 dba at 10 feet.
- Be distinctive from other household sounds.
- Automatically reset under all conditions.
- Be equipped with manual means to temporarily deactivate the alarm for a single opening from either direction.
- Allow deactivation to last not more than 15 seconds.
- Have deactivation touch pads/switches located a minimum of 54 inches above the door threshold.

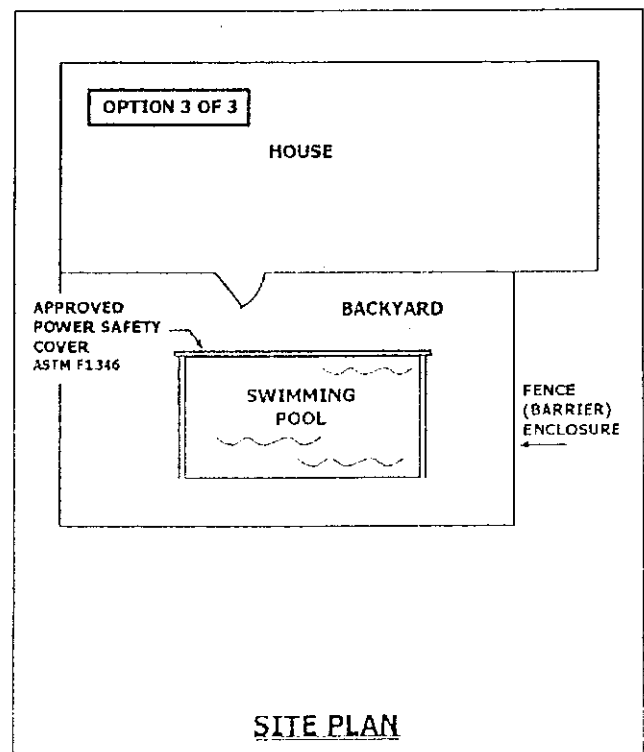
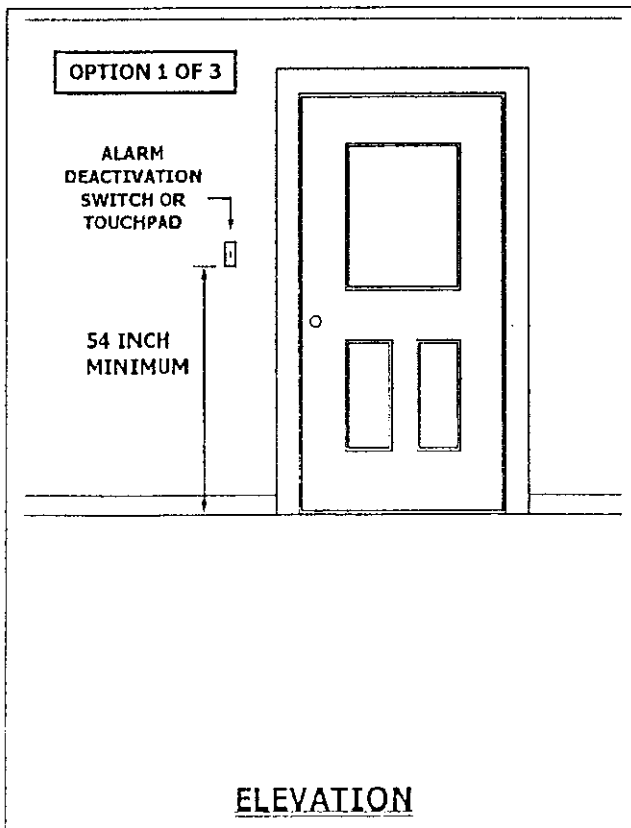
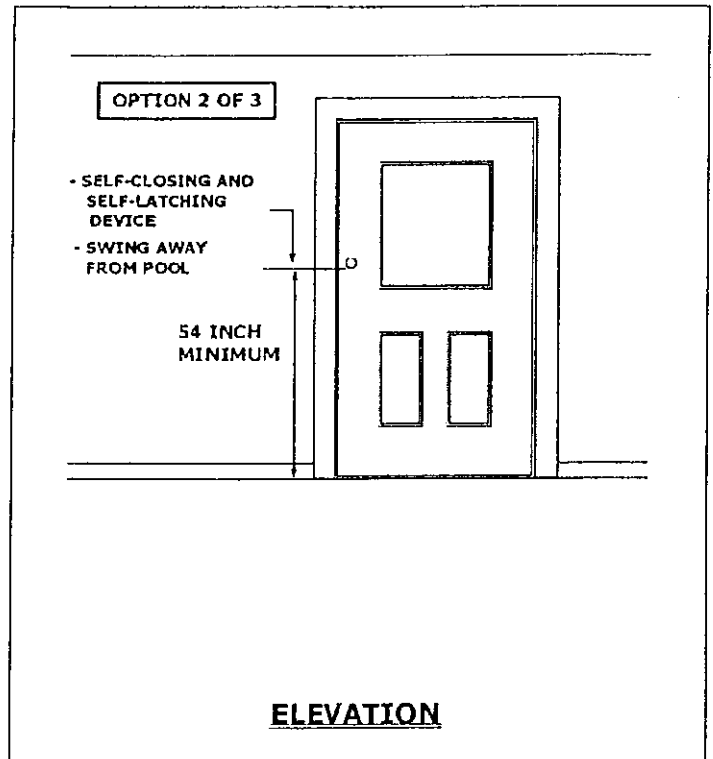

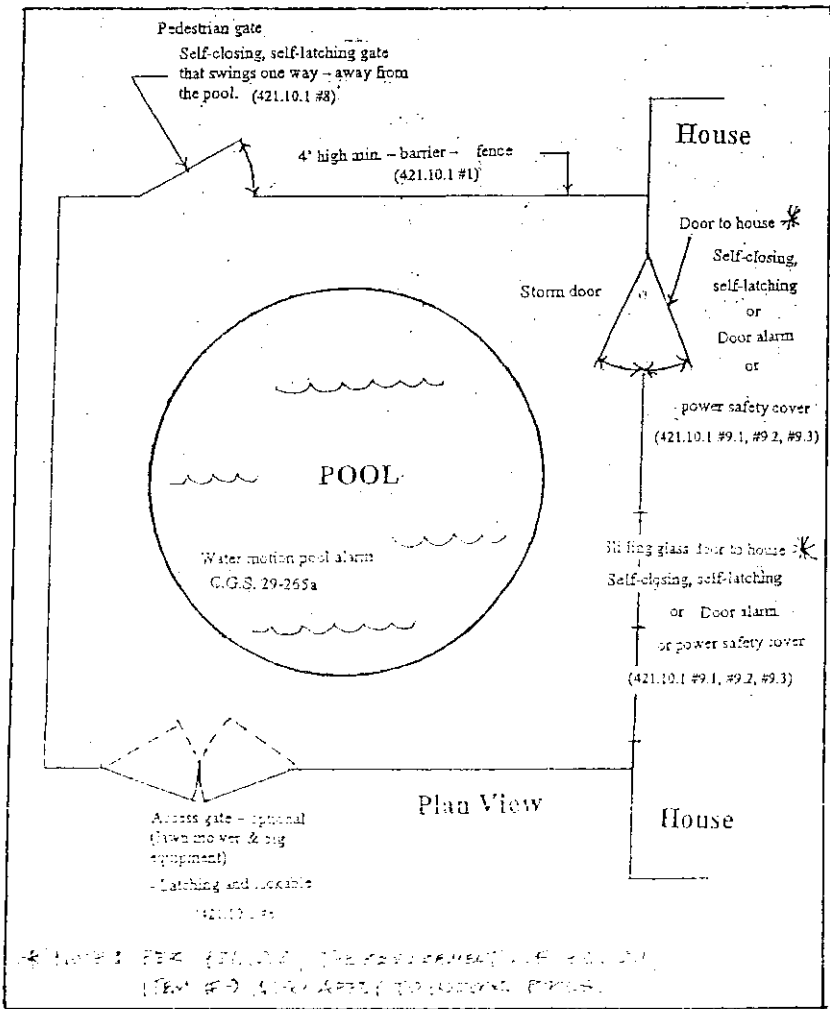
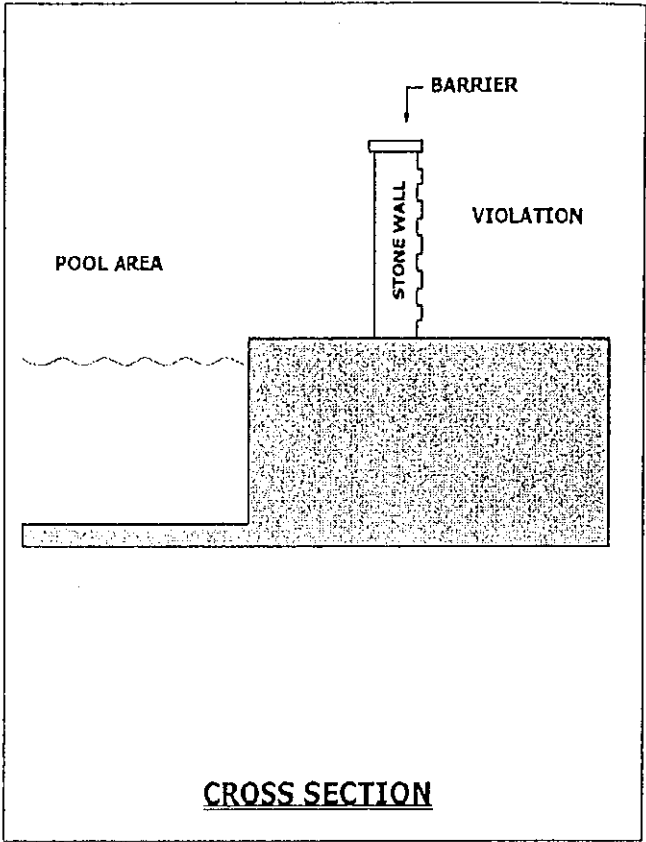
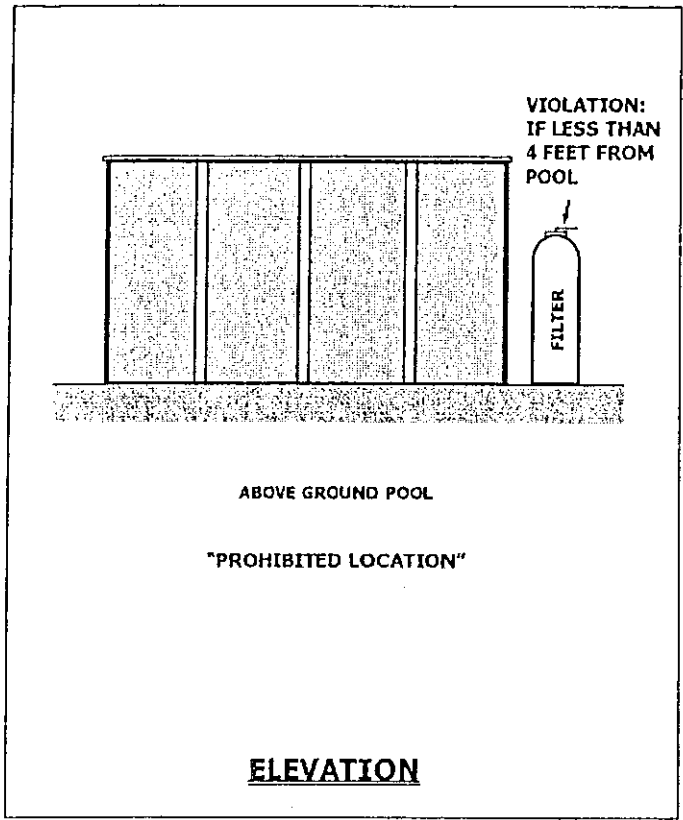

(CT Add – CGS 29-265a)

- Must be on building permit for construction or for substantial alteration
- One or more families - residence
- Must be installed with pool
- 50 db alarm when 15 lbs or more enters pool

Exempt: Hot tubs & portable spas

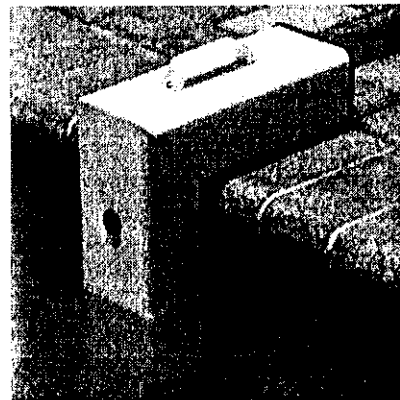
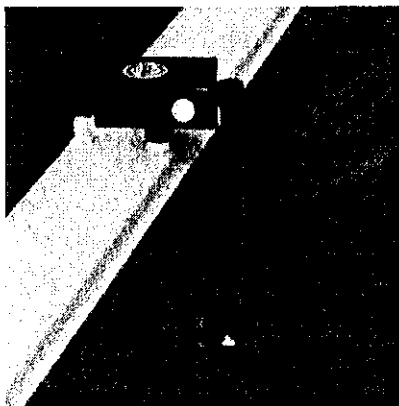

Enclosure (CT Add)

- Must be in place prior to electrical inspections of any in-ground pool
- Min. 48" high
- 4" sphere rule
- Openings with a positive latching device

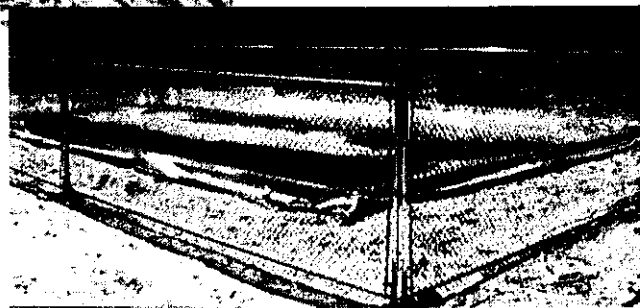

AG 105.3 Indoor
Swimming Pools

Walls surrounding an
indoor pool shall
comply with AG 105.2,
Item 9 (*wall of
dwelling serves as
barrier*)

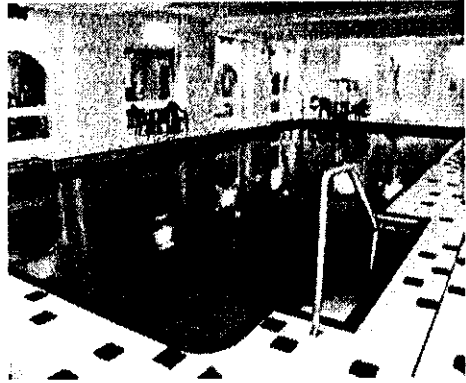

AG105.4 Prohibited locations

Barriers shall be located to prohibit
permanent structures, equipment or
similar objects
from being used
to climb them.



DOOR ALARM

MADE IN THE USA

poolguard™

PBM INDUSTRIES, INC.

MEMBER



NATIONAL SPA & POOL INSTITUTE

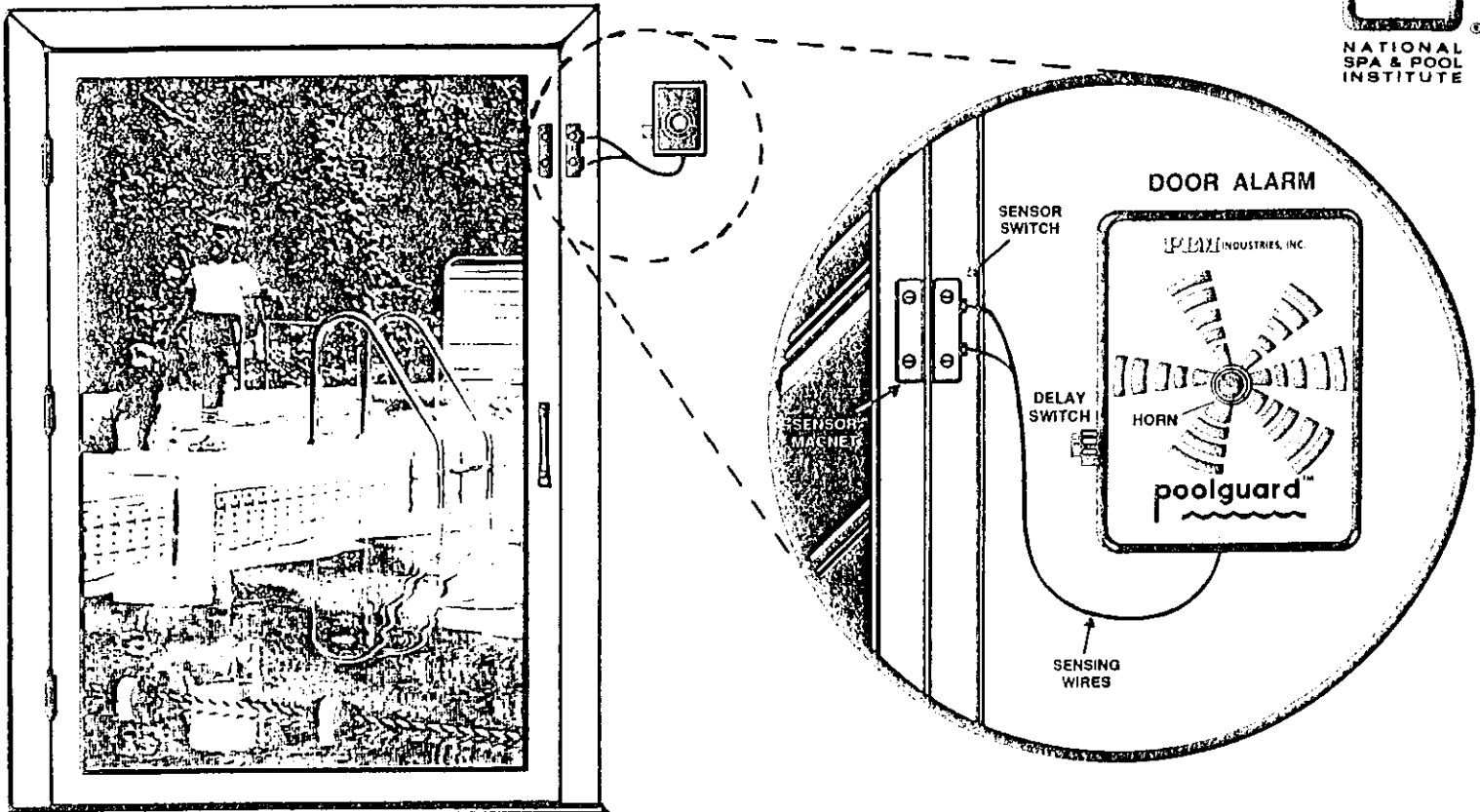

POOLGUARD DOOR ALARM

Poolguard Door Alarm mounts next to any door which gives easy access to your swimming pool. Any door which allows young children easy and quick access to a pool area is dangerous and should have a door alarm. The Poolguard Door Alarm comes with two magnetic switches, hookup wire, and operates on one 9-volt battery. The door alarm has a 15-second delay switch which allows an adult to pass through the door without the alarm sounding. If for any reason the door is accidentally left open the alarm will sound in 15 seconds and continue to sound until the door is shut. For further information contact your local Poolguard distributor or call PBM Industries toll free. When you think of pool safety/security, think of Poolguard.

- Important Safety Feature
- Complies With Model Barrier Codes
- Simple To Operate
- Automatic Reset
- Battery Powered
- Easy To Install
- Affordable Price
- Pass Through Feature For Adults

CALL TOLL FREE: 1-800-242-7163

P.O. Box 658 • North Vernon, IN 47265 • (812) 346-2648

INCREASES POOL SAFETY

Example - AG 105.1 - 9.2

9. Dwelling wall part of barrier

Meeting one of the following:

- 9.1 *Powered* safety cover per ASTM F1346
- 9.2 Doors accessing pool
 - Audible alarm for door & screen, 30 sec
 - Auto reset
 - Manual deactivation for single opening
 - Deactivation switch min. 54" high
- 9.3 Other means of protection acceptable of protection not less than 9.1 or 9.2

9.

